

II B. Tech II Semester Regular Examinations April/May – 2013

CONTROL SYSTEMS

(Com. to EEE, ECE, EIE, ECC, AE)

Time: 3 hours

Max. Marks: 75

Answer any **FIVE** Questions
All Questions carry **Equal** Marks

1. a) What do you mean by closed-loop control system? Give examples of closed-loop control system.
- b) For the mechanical system shown in Figure 1, determine the transfer function $Y_2(s)/F(s)$.

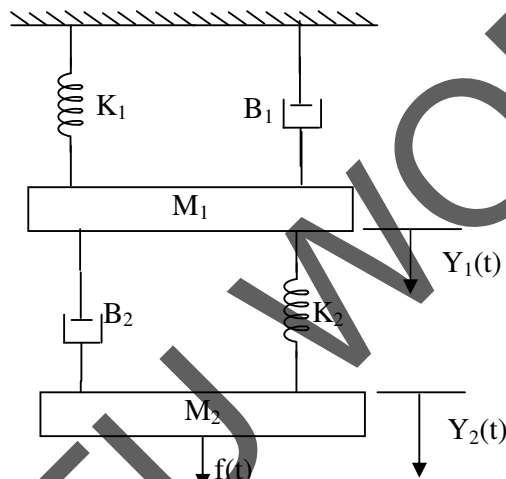

Figure 1

2. a) Obtain the transfer function of an armature voltage controlled DC. servo motor.
- b) Figure 2 shows a block diagram representation of a system. Draw the signal flow graph and find the transfer function $C(s)/R(s)$.

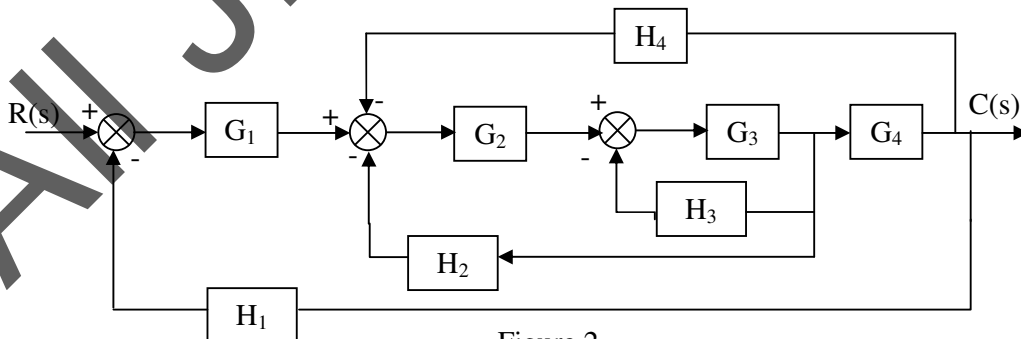
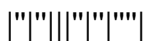

Figure 2



3. a) Define position, velocity and acceleration error constants. Express steady-state error in terms of error constants for type-1 and type-2 systems.
 b) A unity-feedback system is characterized by the open loop transfer function $G(s) = \frac{1}{s(1+0.5s)(1+0.2s)}$. Determine the rise time, peak time, peak overshoot, and settling time of the unit-step response of the system.

4. Draw the root locus of the system whose open loop transfer function is $G(s)H(s) = \frac{K}{s(s+3)(s^2+3s+11.25)}$

5. a) Define the following: (i) resonance frequency, (ii) bandwidth, (iii) cut-off rate, (iv) phase margin and (v) gain margin
 b) Find resonant frequency, resonant peak and band width of a unity feedback system with

$$G(s) = \frac{36}{s(s+8)}$$

6. Using Nyquist stability criterion determine the stability of the closed loop system $G(s)H(s) = \frac{100}{s(s+1)(s^2+2s+2)}$

7. A system has $G(s) = \frac{0.035}{s(1+0.5s)(1+0.04s)}$. Design a suitable lag compensator to give velocity error constant 27.3 s^{-1} and phase margin $= 45^\circ$.

8. The state equation of a linear time-invariant system is given below:

$$\begin{bmatrix} \dot{X}_1 \\ \dot{X}_2 \end{bmatrix} = \begin{bmatrix} -2 & 0 \\ 1 & -1 \end{bmatrix} \begin{bmatrix} X_1 \\ X_2 \end{bmatrix} + \begin{bmatrix} 0 \\ 1 \end{bmatrix} u$$

Determine the following:

- i) State transition matrix
 ii) Controllability and observability of the system

II B. Tech II Semester Regular Examinations April/May – 2013

CONTROL SYSTEMS

(Com. to EEE, ECE, EIE, ECC, AE)

Time: 3 hours

Max. Marks: 75

Answer any **FIVE** Questions
All Questions carry **Equal** Marks

1. a) Give examples of open-loop control system. Discuss the advantages and disadvantages of open-loop control systems.
b) For the mechanical system shown in Figure 1, determine the transfer function $Y_1(s)/F(s)$.

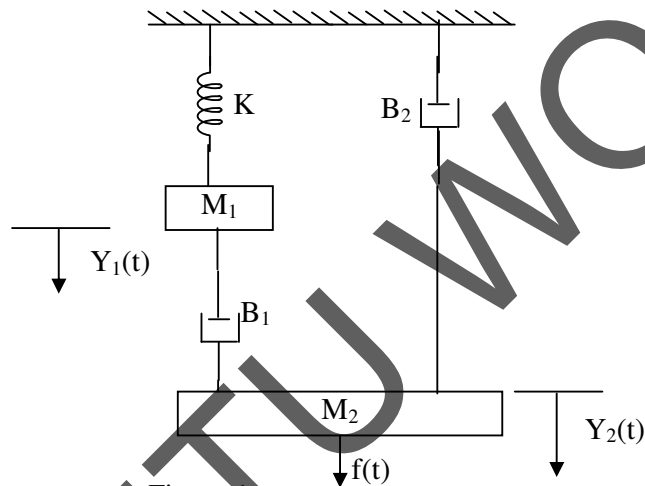

Figure 1

2. a) Explain the principle of operation of AC servo motor.
b) For the signal flow graph shown in Figure 2, obtain the overall gain C/R .

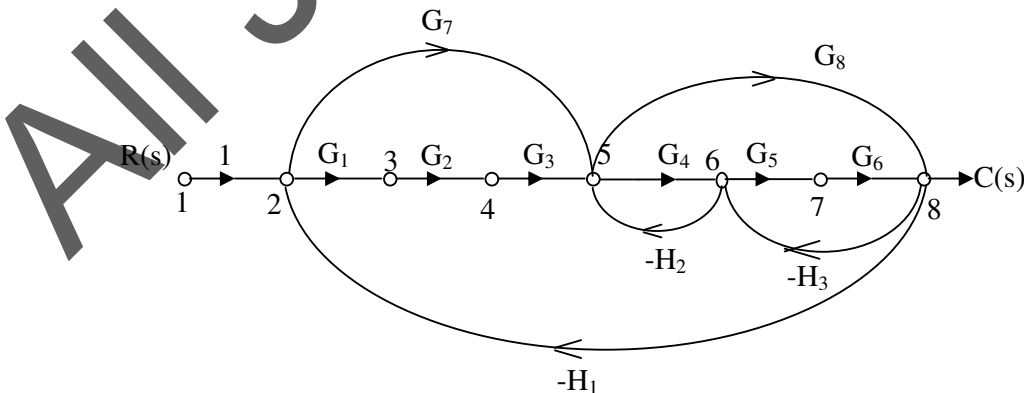

Figure 2

3. a) Consider the closed loop transfer function given by $\frac{C(s)}{R(s)} = \frac{\omega_n^2}{s^2 + 2\xi\omega_n s + \omega_n^2}$. Derive the expression for $c(t)$ when system is subjected to a unit step input.
- b) The open loop transfer function $G(s)$ of a unity feedback control system is $\frac{K}{s(sT+1)}$. The system is critically damped and the steady state error is 0.5 when unit ramp input is applied. Find out the natural frequency of the system.
4. a) Draw the root locus of the system whose open loop transfer function $G(s)H(s) = \frac{K(s+2)(s+3)}{s(s+4)(s+5)}$.
- b) The open loop transfer function of a feedback control system is given by $\frac{K}{s(s+4)(s^2+2s+2)}$. Determine the range of value of K for stability.
5. Draw the Bode plot for the unity feedback system whose transfer function is given as $G(s) = \frac{10(s+10)}{s(s+2)(s+5)}$. From the plot determine the values of gain margin and phase margin. State whether the system is stable or not.
6. For the system with $G(s)H(s) = \frac{10K(s+0.6)}{s^2(s+2)(s+10)}$ using Nyquist stability criterion determine stability with $K=10$.
7. a) What do you mean by compensator? Discuss series and parallel compensators.
b) Discuss about lag compensator. Sketch the Bode plot of a lag compensator. Give the design steps of a lag compensator.
8. a) Obtain the transfer function of the system whose governing equations are as given below:

$$\dot{x}_1 = -4x_1 - x_2 + 3u$$

$$\dot{x}_2 = 2x_1 - 3x_2 + 5u$$

$$y = x_1 + 2x_2$$

- b) Find the controllability of the system represented by $\begin{bmatrix} \dot{X}_1 \\ \dot{X}_2 \end{bmatrix} = \begin{bmatrix} 1 & 2 \\ 0 & -1 \end{bmatrix} \begin{bmatrix} X_1 \\ X_2 \end{bmatrix} + \begin{bmatrix} 1 \\ 0 \end{bmatrix} u$.

II B. Tech II Semester Regular Examinations April/May – 2013

CONTROL SYSTEMS

(Com. to EEE, ECE, EIE, ECC, AE)

Time: 3 hours

Max. Marks: 75

Answer any **FIVE** Questions
All Questions carry **Equal** Marks

1. a) Show that feedback results in reduction of overall gain and reduction of system sensitivity to parameter changes.
b) Find the transfer function E_o/E_i of the circuit given in Figure 1.

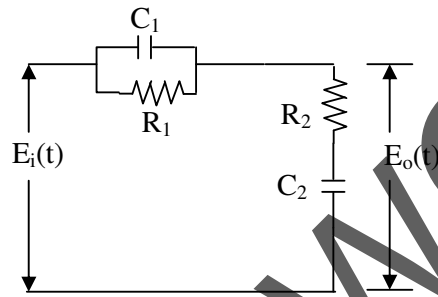

Figure 1

2. a) Explain the working of a synchro transmitter and receiver.
b) Define the following: (i) signal-flow graph, (ii) source node, (iii) sink node, (iv) path gain and (v) loop gain.
3. a) What are integral controllers and why are they used in combination with proportional controllers?
b) For a system having $G(s)H(s) = \frac{20}{s^2 + 7s + 25}$, find its time response specifications.
4. The open loop transfer function of a system with unity feedback is $\frac{K(s+2)}{s^2 + 2s + 3}$. Draw the root locus of the above system.
5. a) Define (i) Bode plot, (ii) phase margin, (iii) minimum phase function and (iv) all-pass function.
b) Establish the correlation between time and frequency domain specifications for a second-order system.

6. The loop transfer function of a certain control system is given by

$$G(s)H(s) = \frac{4s+1}{s^2(s+1)(2s+1)}$$

Using Nyquist stability criterion, determine the stability of the closed loop system whose open loop transfer function is given above.

7. The open loop transfer function of a unity feedback control system is $G(s) = \frac{12}{s(s+2)}$.

Design a lead compensation such that the closed-loop system satisfies the following specifications: $K_v = 24 \text{ s}^{-1}$, phase margin = 55° and gain margin $\geq 13 \text{ dB}$.

8. a) Find the transfer function when

$$\begin{bmatrix} \dot{X}_1 \\ \dot{X}_2 \end{bmatrix} = \begin{bmatrix} -2 & 1 \\ 0 & -3 \end{bmatrix} \begin{bmatrix} X_1 \\ X_2 \end{bmatrix} + \begin{bmatrix} 0 \\ 1 \end{bmatrix} u$$

$$Y = \begin{bmatrix} 1 & 1 \end{bmatrix} \begin{bmatrix} X_1 \\ X_2 \end{bmatrix}$$

- b) A system is described by $\frac{d^3y}{dt^3} + 6\frac{d^2y}{dt^2} + 11\frac{dy}{dt} + 2y = 6u$, where y is the output and u is the input of the system. Obtain the state space representation of the system.

II B. Tech II Semester Regular Examinations April/May – 2013

CONTROL SYSTEMS

(Com. to EEE, ECE, EIE, ECC, AE)

Time: 3 hours

Max. Marks: 75

Answer any **FIVE** Questions
All Questions carry **Equal** Marks

1. a) Discuss about the classification of control systems.
b) Obtain $E_o(S)/E_i(S)$ of the below electrical system (Figure 1).

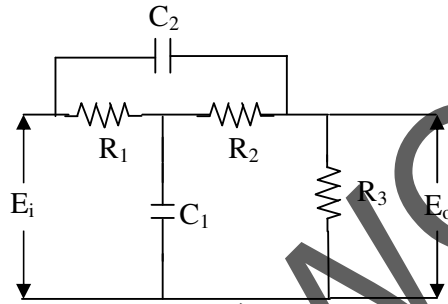

Figure 1

2. a) An armature controlled dc motor has an armature resistance of 0.37Ω . The moment of inertia is $2.5 \times 10^{-6} \text{ kg-m}^2$. A back e.m.f of 209 V is generated per 100 rpm of the motor speed. The torque constant of the motor is 0.2 N-m/ampere. Determine the transfer function of the motor relating the motor shaft shift and the input voltage.
b) Find the overall gain $C(S)/R(S)$ for the block diagram shown in Figure 2.

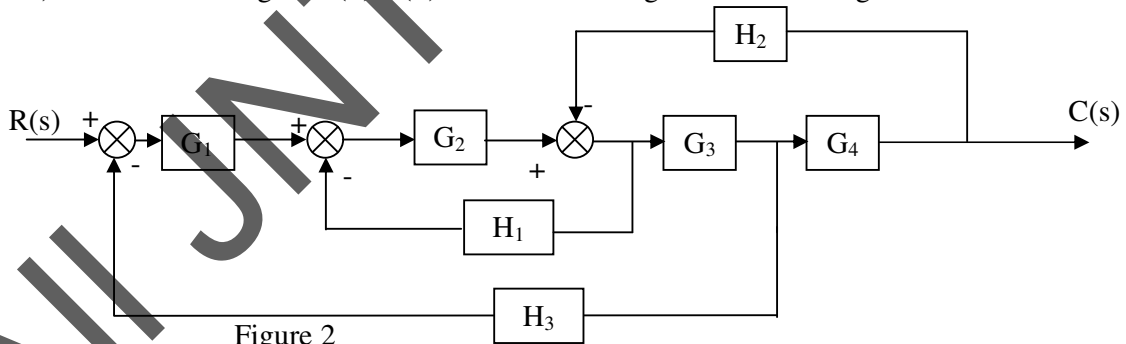

Figure 2

3. a) What are derivative controllers and why are they used in combination with proportional controllers?
b) For a system having $G(s) = \frac{25}{s(s+10)}$ and unity negative feedback, find (i) ω_n , (ii) ζ , (iii) ω_d , (iv) T_p and (v) M_p .

4. The open loop transfer function of a feedback control system is given by $G(s)H(s) = \frac{K}{s(s+3)(s^2+2s+2)}$. Draw the root locus as K varies from 0 to ∞ . Also calculate the value of K for which the system becomes oscillatory.

5. Draw Bode plot for a control system having transfer function $G(s)H(s) = \frac{100}{s(s+1)(s+2)}$. Determine (i) gain margin, (ii) phase margin, (iii) gain cross-over frequency, and (iv) phase cross over frequency.

6. a) Find the polar plot of system whose open loop transfer function is $G(s) = \frac{14}{s(s+1)(s+2)}$.
 b) The open loop transfer function of a negative feedback system is given as $G(s)H(s) = \frac{K}{(1+T_1s)(T_2s+1)}$. Examine the stability of the closed loop system using Nyquist stability criterion.

7. The open loop transfer function of a unity feedback control system is $G(s) = \frac{4}{s(s+2)}$. Design a compensator to meet the following specifications: $K_v = 20$, phase margin = 50° and gain margin of at least 10 dB.

8. a) List out the properties of state transition matrix.
 b) Obtain the time response of the following system:

$$\begin{bmatrix} \dot{X}_1 \\ \dot{X}_2 \end{bmatrix} = \begin{bmatrix} 0 & 3 \\ -2 & -5 \end{bmatrix} \begin{bmatrix} X_1 \\ X_2 \end{bmatrix} + \begin{bmatrix} 0 \\ 2 \end{bmatrix} u$$

where $u(t)$ is input step function occurring at $t=0$.